

### Heavy Duty Brackets

#### Features

- ▶ Material: 3/16" (5 mm) Steel
- ▶ Mounting:  
Wall: use 5/16" lag screws  
Shelf: use #8 wood screws
- ▶ Finish: epoxy coated, black or white

#### Applications

- ▶ Counter tops
- ▶ Work surfaces
- ▶ Book shelves
- ▶ Closet shelves

#### Dimensions

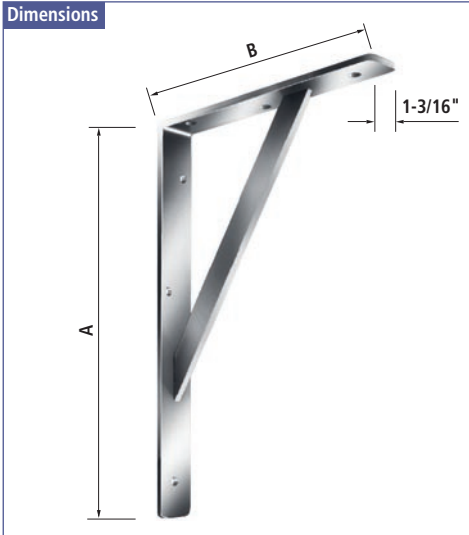

Item-No.	Dimensions A x B		Finish
	inch	mm	
72531 80 078	11-13/16 x 8-1/4	300 x 210	Black
72531 82 077	11-13/16 x 8-1/4	300 x 210	White
72531 80 080	15-3/4 x 10-5/8	400 x 270	Black
72531 82 079	15-3/4 x 10-5/8	400 x 270	White
72531 80 082	19-11/16 x 13	500 x 330	Black
72531 82 081	19-11/16 x 13	500 x 330	White
72531 80 084	21-11/16 x 14-3/16	550 x 360	Black
72531 82 083	21-11/16 x 14-3/16	550 x 360	White



### Folding Bracket · 72531 03 088

#### Dimensions

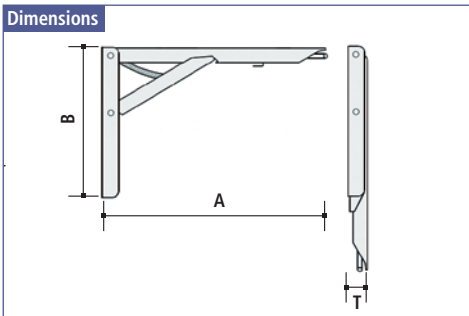

#### Features

- ▶ Material: Steel
- ▶ Spring held in close position
- ▶ Finish: yellow zinc

Item-No.	Size		A		B		T	
	inch	mm	inch	mm	inch	mm	inch	mm
72531 03 088	10	250	10	250	3-1/4	83	1/2	12

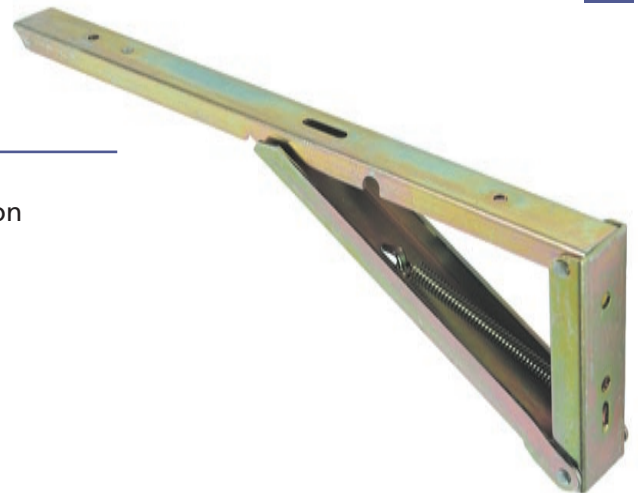

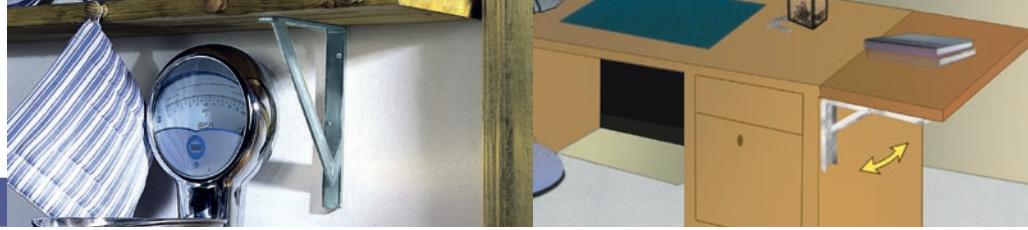

### Stainless Steel Folding Bracket

#### Features

- ▶ Material: Stainless Steel
- ▶ Adjusts in 90°, 80° and 70° angle
- ▶ Spring held in close position



#### Dimensions

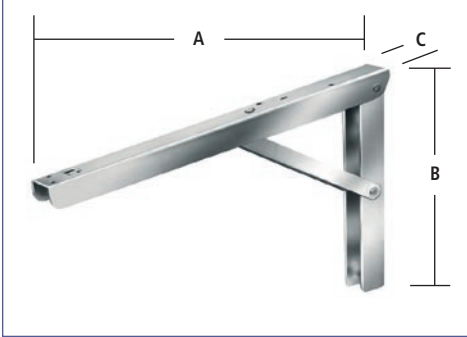

Item-No.	A		B		C	
	inch	mm	inch	mm	inch	mm
72531 56 075	11-7/8	300	7-7/8	200	1-1/8	30
72531 56 076	15-3/4	400	10-7/8	275	1-3/8	35

#### 3 Angle Adjust

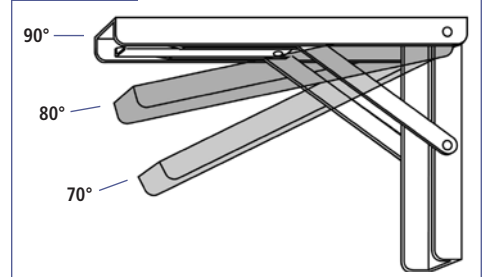

#### Applications

- ▶ Counter tops
- ▶ Work surfaces
- ▶ Book shelves
- ▶ Closet shelves
- ▶ Marine industry
- ▶ Outdoor Kitchens

